

FEATURES

- Operating Frequency Range: DC to 7.0GHz
- Operating Drain Voltage: 28V & 50V
- Maximum Output Power (PSAT): 30W
- Surface Mount Plastic Package
- Suitable for Pulsed, Linear applications
- 100% DC & RF Production Tested

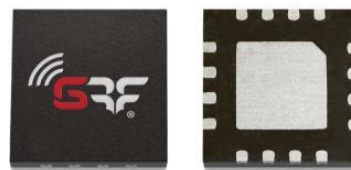

16 Pin 3x3 mm QFN Package

DESCRIPTION

The GRF0020 is a 30W (P3dB) unmatched discrete GaN-on-SiC HEMT which operates from DC to 7.0GHz on a 50V supply rail. The wide bandwidth of the GRF0020 makes it suitable for a variety of applications including cellular infrastructure, radar, communications, and test instrumentation, and can support both linear and pulse operations. The device is housed in an industry-standard 3x3 mm surface mount QFN-16 package. Lead-free and RoHS compliant.

Typical Performances 1 Tone pulsed CW (10% duty cycle, 100μs width), *2nd Harmonics NOT optimized*

(1) Optimum Peak Power at 2.5dB in compression

(2) Optimum Peak Efficiency at 2.5dB in compression

V_{ds} = 50V, I_{dq} = 30mA, T_A = 25°C

V_{ds} = 28V, I_{dq} = 30mA, T_A = 25°C

Frequency (MHz)	P _{out} ⁽¹⁾ (dBm)	Gain ⁽²⁾ (dB)	Eff ⁽²⁾ (%)
1000	45.0	24.3	65.7
1400	44.9	22.1	66.9
1800	45.1	19.8	63.7
2200	45.1	19.6	60.7
2600	45.2	18.8	64.3
3000	45.4	18.7	63.8
4000	45.4	17.2	65
5000	45.1	15.1	60
5500	45.2	14.2	60.6
6000	45.3	13.8	61.6

Frequency (MHz)	P _{out} ⁽¹⁾ (dBm)	Gain ⁽²⁾ (dB)	Eff ⁽²⁾ (%)
1000	42.2	20.5	69.1
1400	42.3	19.5	69.1
1800	42.6	18.4	67.5
2200	42.6	17.7	61.7
2600	42.8	17.4	65.7
3000	42.8	16.8	65.8
4000	42.7	14.9	65.9
5000	42.5	12.6	61.5
5500	42.5	12	62.7
6000	42.6	11.8	63.6

GRF0020 50V, DC – 7.0GHz, 20W GaN HEMT

ABSOLUTE MAXIMUM RATINGS^(1,2)

Parameter	Rating	Symbols / Units
Drain Source Voltage	150	V_{DS} (V)
Gate Source Voltage	-8 to +2	V_{GS} (V)
Operating Voltage	55	V_{dsq} (V)
Junction Temperature	+225	T_{JUNC} (°C)
Storage Temperature	-65 to +150	$T_{STORAGE}$ (°C)
Case Temperature	-40 to +105	T_{CASE} (°C)

Notes: 1. Exceeding any of these limits may cause permanent damage to the device or reduce the lifetime (MTTF). 2. GRF does not recommend sustained operation above maximum operating conditions

BLOCK DIAGRAM

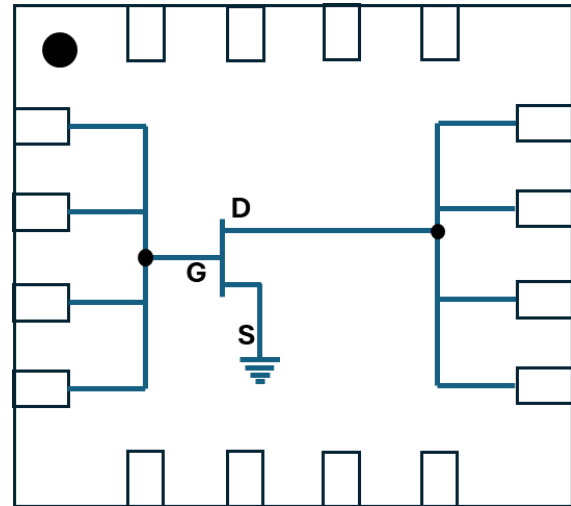
ELECTRICAL SPECIFICATIONS: $T_A = 25^\circ\text{C}$

Parameter	Min	Typ	Max	Symbols/Units	Test Conditions
Frequency Range	DC		7000	MHz	
DC Characteristics					
Drain Source Breakdown Voltage	150			V_{BDSS} (V)	
Drain Source Leakage Current		50		I_{DLK} (uA)	$V_{GS} = -8V, V_{DS} = 50V$
Gate Threshold Voltage	-3.4		-1.5	V_{GS} (V)	$V_{DS} = 50V$
Operating Conditions					
Gate Bias Voltage		-2.5		V_{GS} (V)	
Drain Voltage		50		V_{DS} (V)	
Quiescent Drain Current		30		I_{DQ} (mA)	



GRF0020 50V, DC – 7.0GHz, 20W GaN HEMT

RF ELECTRICAL SPECIFICATIONS: $T_A = 25^\circ\text{C}$, $V_{DS} = 50\text{V}$, $I_{DQ} = 30\text{mA}$, $\text{Freq} = 3000\text{MHz}$

Parameter	Symbol	Min.	Typ.	Max.	Units	Conditions
Small Signal Gain	G_{SS}		15		dB	@ $I_{DS} \leq 1.1 * I_{DQ}$
Power Gain	G_{MAX}		16.0		dB	Max gain vs. power
Saturated Gain	G_{SAT}		13.5		dB	@2.5dB compression referenced to G_{MAX}
Saturated Drain Efficiency	$DEff_{SAT}$		51		%	
Saturated Output Power	P_{SAT}		45		dBm	
Ruggedness	ψ	@2.5dB compression; Output VSWR = 10:1, all angles				No damage or shift in performance

1. 1 Tone Pulse CW, pulse width 100us, duty cycle 10%
2. Performance based on GRF EVB, 50Ω system

THERMAL AND RELIABILITY INFORMATION - CW ^(1, 2, 3): $T_c = 85^\circ\text{C}$

Parameter	Test Condition	Value	Units
Channel Temperature	Pdiss 18W	TBD	°C
Rth		TBD	°C/W
Rsur		TBD	°C/W
MTTF		TBD	Hrs



GRF0020 50V, DC – 7.0GHz, 20W GaN HEMT

LOADPULL MEASUREMENT, Vds = 50V Idq = 30mA

1 Tone Pulse CW, pulse width 100us, duty cycle 10%

For Optimum Peak Power @ 2.5dB Compression

Freq-MHz	Zin_F0	Zl_F0	Gain-dB	Pout-dBm	Pout-W	Eff-%	AMPM-deg
1000	3.7 j -17.8	26.1 j 11.4	23.7	45	31.3	61.1	-0.2
1200	4.8 j -16.0	23.5 j 8.0	21.6	44.8	30.5	58	1.8
1400	4.1 j -13.3	22.5 j 9.0	21.2	44.9	31.2	56.8	1.7
1600	4.0 j -10.9	19.0 j 8.2	20.4	45.3	34.1	55	1.2
1800	2.9 j -8.6	19.3 j 11.0	19.6	45.1	32.3	55.7	2.3
2000	3.7 j -7.2	25.5 j 8.6	17.5	44.8	30.9	51	4.8
2200	2.3 j -6.0	14.4 j 7.4	18.3	45.1	32.1	48.8	2.6
2400	2.2 j -4.5	14.2 j 9.8	19.3	45	31.3	51.6	1.4
2600	2.5 j -3.1	17.5 j 10.8	18.4	45.2	33.5	57.2	2.6
2800	2.1 j -2.0	15.4 j 7.2	17	45.4	34.8	52.8	2.6
3000	1.9 j -0.8	16.2 j 5.4	17	45.4	34.4	51.4	1
3500	1.8 j 2.0	10.6 j 5.3	16.5	45.3	34	52.6	-0.5
4000	2.1 j 4.7	10.2 j 4.8	16.1	45.4	34.5	55.8	-1.3
4500	2.1 j 7.6	8.5 j 4.4	14.8	45.2	33.4	55.9	-1.6
5000	2.6 j 10.3	9.5 j 0.4	13.7	45.1	32.8	51.7	-1.1
5500	3.0 j 12.6	8.3 j -1.1	13	45.2	33	53.2	-1.9
6000	3.8 j 17.8	8.6 j -3.4	12.4	45.3	34.3	54.8	-1.8

For Optimum Peak Efficiency @ 2.5dB Compression

Freq-MHz	Zin_F0	Zl_F0	Gain-dB	Pout-dBm	Pout-W	Eff-%	AMPM-deg
1000	3.3 j -15.5	33.9 j 25.7	24.3	43.6	23.4	65.7	-1.4
1200	3.7 j -13.2	31.7 j 26.2	22.5	43.7	23.4	64.5	0.6
1400	3.4 j -11.9	25.1 j 19.8	22.1	44.6	29	66.9	1.3
1600	3.8 j -8.7	28.2 j 27.6	19.9	44	25.1	66.4	1.7
1800	3.0 j -6.7	23.9 j 25.9	19.8	44	25.2	63.7	4.8
2000	3.1 j -6.2	20.6 j 22.5	19.2	44.2	26.2	60.4	4.3
2200	2.2 j -4.5	14.4 j 20.9	19.6	44	25.3	60.7	3.2
2400	2.0 j -3.3	13.5 j 19.8	19.3	44	25.3	59.2	4.3
2600	2.1 j -2.2	14.9 j 18.8	18.8	44.6	29	64.3	4.2
2800	1.7 j -0.7	12.5 j 17.1	18.9	44.6	29.3	63.2	2.4
3000	1.5 j 0.7	11.2 j 17.3	18.7	44.2	26.3	63.8	1.5
3500	1.5 j 3.3	6.8 j 10.9	17.7	44.3	27.3	62.6	-0.4
4000	1.6 j 5.9	6.3 j 9.5	17.2	44.1	25.8	65	-1
4500	1.9 j 8.1	5.1 j 6.2	15.8	44.2	26.3	61.2	-2.1
5000	1.9 j 11.6	5.1 j 3.7	15.1	44	25.4	60	-2
5500	2.4 j 13.8	4.5 j 0.8	14.2	44.2	26	60.6	-3.1
6000	3.0 j 19.1	5.1 j -1.5	13.8	44.5	28.1	61.6	-2.6

GRF0020 50V, DC – 7.0GHz, 20W GaN HEMT

LOADPULL MEASUREMENT, Vds = 28V Idq = 30mA

1 Tone Pulse CW, pulse width 100us, duty cycle 10%

For Optimum Peak Power @ 2.5dB Compression

Freq-MHz	Zin_F0	ZI_F0	Gain-dB	Pout-dBm	Pout-W	Eff-%	AMPM-deg
1000	4.7 j -18.2	18.3 j 1.6	21.2	42.2	16.8	63.2	-0.3
1200	4.0 j -16.0	13.9 j 0.9	19.6	42.1	16.4	54.8	1.9
1400	3.5 j -12.6	16.9 j 4.2	19.7	42.3	17.3	63.5	1.1
1600	3.2 j -9.9	13.5 j 2.8	18.4	42.6	18.2	59.3	-1.3
1800	3.1 j -8.5	15.7 j 3.6	18.4	42.6	18.3	58.8	1.3
2000	3.1 j -7.1	17.2 j 2.7	17.2	42.4	17.3	54.4	2.9
2200	3.0 j -5.6	16.5 j 1.5	16.9	42.6	18.1	55.3	2
2400	2.7 j -4.4	16.5 j 1.5	16.4	42.4	17.5	53.3	2.5
2600	1.9 j -2.9	12.5 j 3.9	17.7	42.8	19	59.8	0.8
2800	2.2 j -1.8	13.5 j 1.7	16.7	42.9	19.2	56.9	0.3
3000	2.2 j -0.6	16.0 j 0.9	15.7	42.8	19	57.5	0.1
3500	2.0 j 2.1	10.9 j 1.3	15.4	42.9	19.4	58.5	-1.7
4000	1.8 j 5.1	11.3 j -0.4	14.3	42.7	18.9	58.2	-1.6
4500	2.2 j 7.5	10.0 j -1.0	13.2	42.6	18.5	57.4	-2.3
5000	2.2 j 10.7	9.8 j -4.2	12.4	42.5	18.1	55.6	-2.2
5500	2.6 j 13.1	9.9 j -6.9	11.3	42.5	18.2	53.6	-2.5
6000	3.2 j 18.8	10.1 j -7.5	11	42.6	18.7	58.4	-2.3

For Optimum Peak Efficiency @ 2.5dB Compression

Freq-MHz	Zin_F0	ZI_F0	Gain-dB	Pout-dBm	Pout-W	Eff-%	AMPM-deg
1000	4.6 j -16.5	30.3 j 3.7	20.5	41.4	14.1	69.1	2.1
1200	4.3 j -13.4	29.8 j 8.2	19.7	41.1	12.8	67.7	3.8
1400	3.3 j -10.9	25.3 j 13.4	19.5	41.2	13.2	69.1	2.8
1600	3.6 j -8.1	20.7 j 11.6	18.4	41.4	14	69.6	-1.9
1800	2.7 j -6.0	17.9 j 16.3	18.4	40.8	12.3	67.5	1.5
2000	2.1 j -4.9	16.0 j 16.2	18	40.6	11.7	59.5	3.2
2200	1.9 j -4.2	16.2 j 10.0	17.7	41.9	15.9	61.7	2.5
2400	2.0 j -3.5	14.8 j 10.9	17.6	41.7	14.8	60.6	2.6
2600	1.7 j -1.5	13.1 j 13.5	17.4	41.2	13.3	65.7	2.4
2800	1.5 j 0.1	11.8 j 11.9	17.2	41.5	14.1	65.5	0.8
3000	1.5 j 1.1	12.0 j 11.6	16.8	41.3	13.4	65.8	0.1
3500	1.6 j 3.4	8.7 j 6.4	15.3	42	16.1	66.1	-2
4000	1.6 j 6.3	8.2 j 5.0	14.9	41.6	14.9	65.9	-2.6
4500	1.8 j 9.2	5.4 j 3.0	13.9	41	12.7	64.2	-4.6
5000	2.1 j 11.9	7.0 j 1.1	12.6	41.3	13.7	61.5	-2.7
5500	2.3 j 14.5	5.4 j -2.6	12	41.3	13.6	62.7	-5.9
6000	2.9 j 20.0	5.7 j -5.0	11.8	41.4	13.9	63.6	-4.8

GRF0020 50V, DC – 7.0GHz, 20W GaN HEMT**LOADPULL MEASUREMENT NOTES**

Source and Load impedance @ 2nd Harmonic are set to 10 Ohms

With proper 2nd Harmonic termination, expect +5% Efficiency for Source and similar with Drain 2nd Harmonic.

Z_{LOAD} : Measured Impedance presented to the output of the device in the reference plane

Z_{IN} : Measured input Impedance at the input of the device in the reference plane

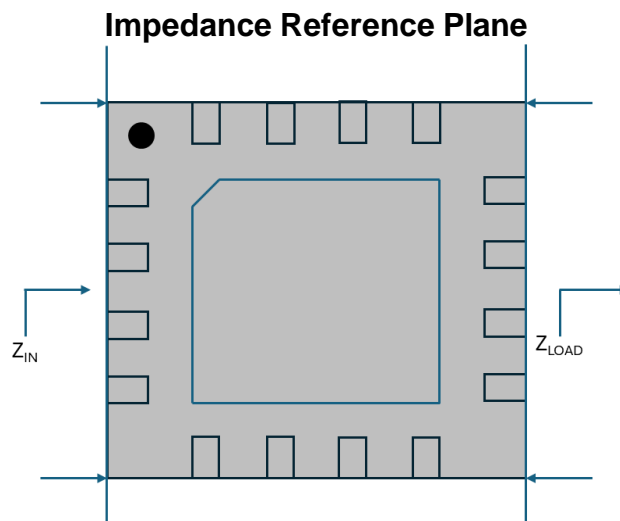

Raw data and full Loadpull measurement report available at request: sales@guerrilla-rf.com



GRF0020 50V, DC – 7.0GHz, 20W GaN HEMT

**BROADBAND S-PARAMETERS MEASUREMENT, $V_{ds} = 28$ & $50V$ $I_{dq} = 30mA$
1 Tone CW**

S-Parameters (Mag-dB)

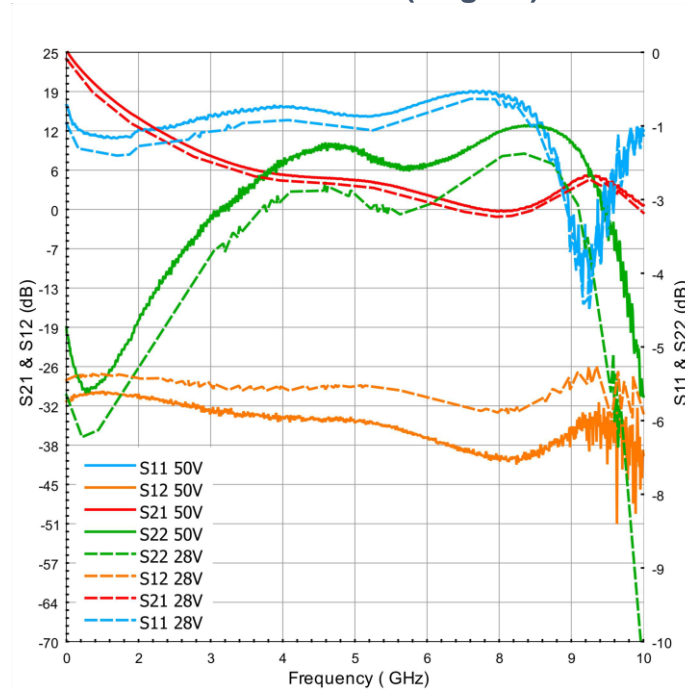

S11 & S22 0.4-6 GHz

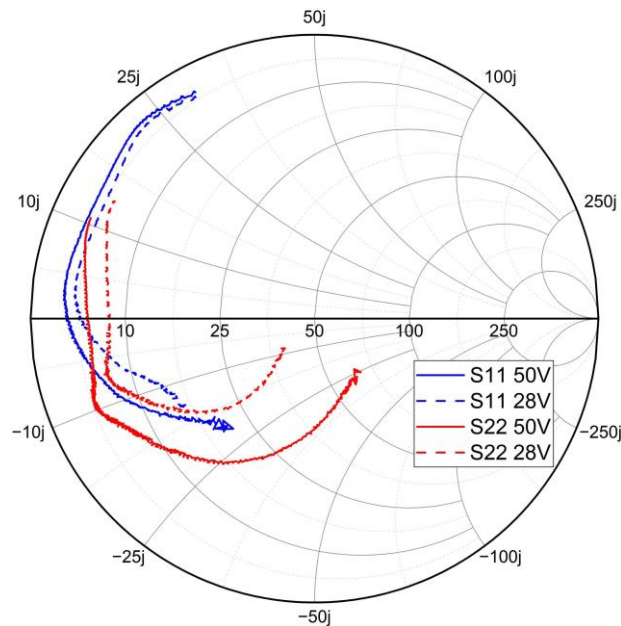



GRF0020 50V, DC – 7.0GHz, 20W GaN HEMT

BROADBAND S-PARAMETERS MEASUREMENT, $V_{ds} = 28 \text{ \& 50V}$ $I_{dq} = 30\text{mA}$
 1 Tone CW

Maximum Available Gain

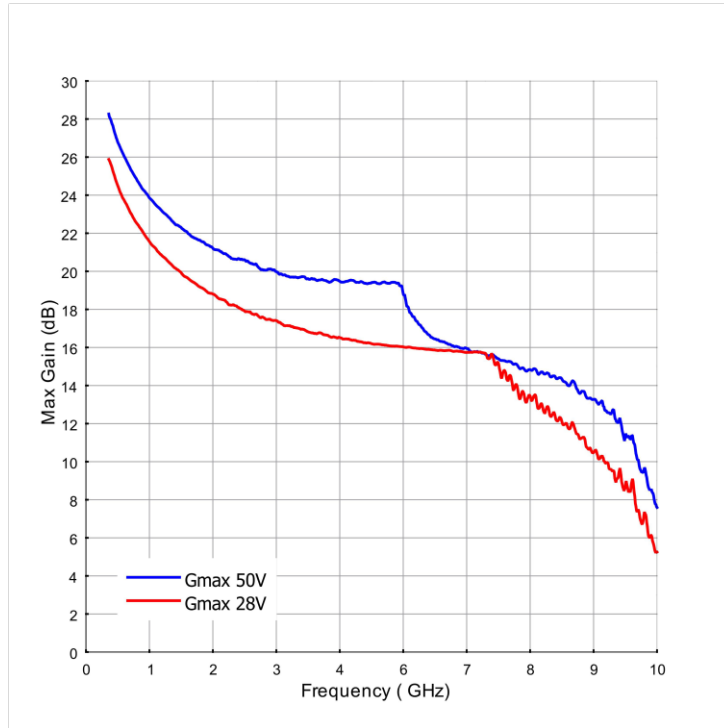

K Factor

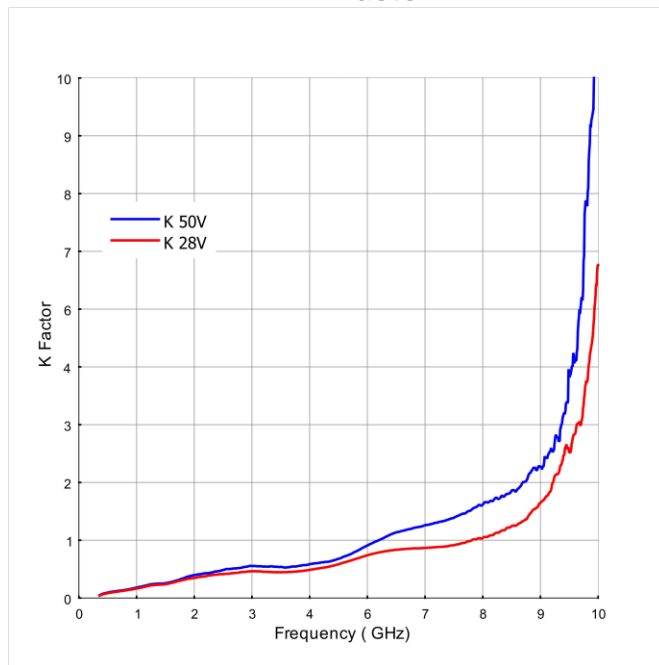

GRF0020 50V, DC – 7.0GHz, 20W GaN HEMT

EVALUATION TEST FIXTURE 2.3 - 3.8 GHZ

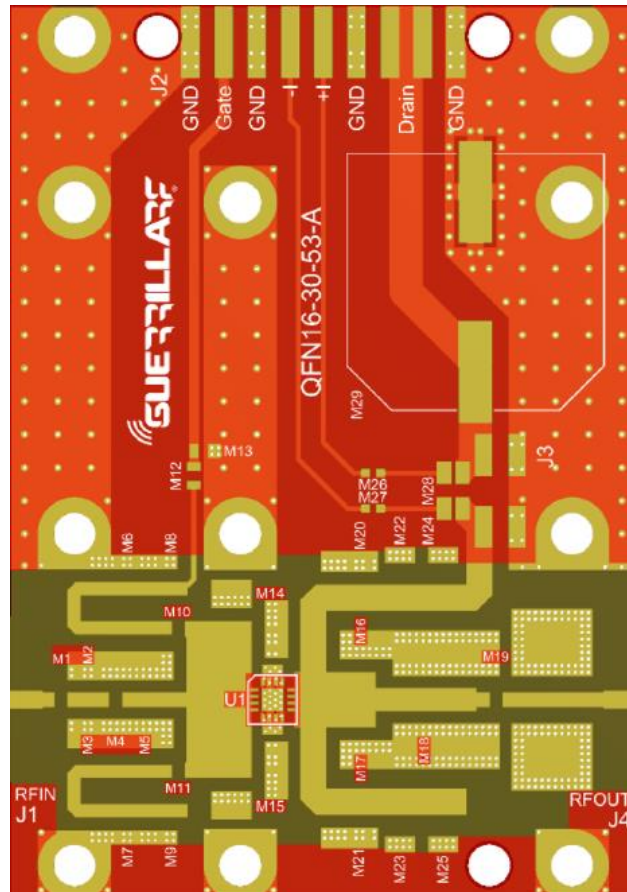

REFERENCE DESIGNATOR	TYPE	VALUE	SIZE	MANUFACTURER	ALTERNATE
EVB	PCB			Guerrilla-RF	Yes
U1	GaN PA GRF0020		3x3mm	Guerrilla-RF	No
M1	Resistor	2Ω	0805	Various	
M2/M3	Resistor	1kΩ	0805	Various	
M4	Capacitor	3.0pF	0805	ATC	Ok (Murata)
M5	Capacitor	1.2pF	0805	ATC	Ok (Murata)
M6	Capacitor	6.8pF	0805	ATC	Ok (Murata)
M7/M9/M11/M16/M17	DNP				
M8	Capacitor	10nF	0805	Murata	Ok
M10	Resistor	5.1Ω	0805	Various	
M12	Resistor	0Ω	0805	Various	
M13	Capacitor	10uF	0805	Murata	Ok
M14/M15	Capacitor	0.5pF	0805	ATC	Ok (Murata)
M18	Capacitor	0.6pF	0805	ATC	Ok (Murata)
M19	Capacitor	6.8pF	0805	ATC	Ok (Murata)
M20/M21	Capacitor	6.8pF	0805	ATC	Ok (Murata)
M22/M23/M24/M25	Capacitor	10uF	1210	Murata	Ok
M26/M27	Resistor	1kΩ	0603	Various	
M28	Resistor	10mΩ	1206	Ohmite	Ok
M29	Electrolytic Capacitor	220uF	12.5mm	Various	
J3	DNP				
J2	DC Connector			Various	
J1/J4	SMA			Various	



GRF0020 50V, DC – 7.0GHz, 20W GaN HEMT

Typical Performance Curves as Measured in the 2.3 - 3.8 GHz Evaluation Test Fixture:

Pulsed CW (10% duty cycle, 100µs width), VDS = 50V, IDQ = 30mA, TC = 25°C (Unless Otherwise Noted)

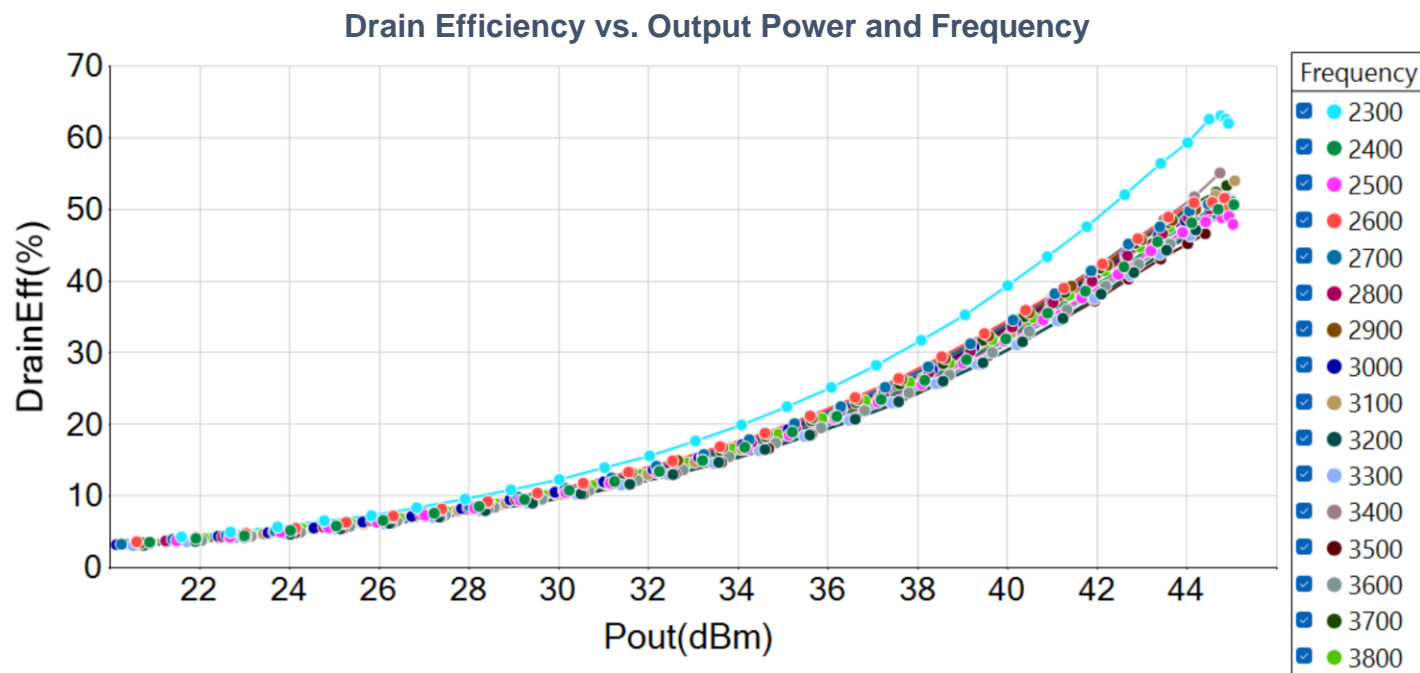
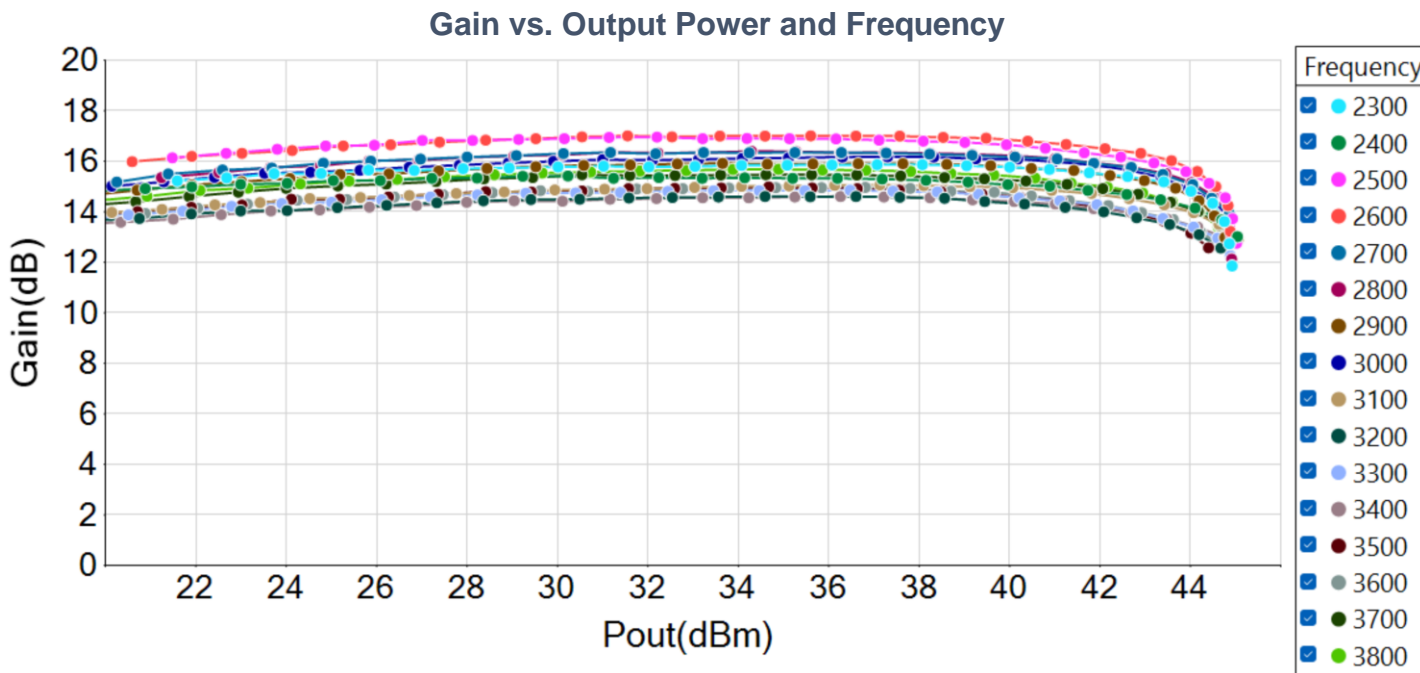



GRF0020 50V, DC – 7.0GHz, 20W GaN HEMT

Typical Performance Curves as Measured in the 2.3-3.7 GHz Evaluation Test Fixture:
 Pulsed CW (10% duty cycle, 100µs width), VDS = 50V, IDQ = 30mA, TC = 25°C (Unless Otherwise Noted)

Gain vs. Frequency, 2.5dB Compression

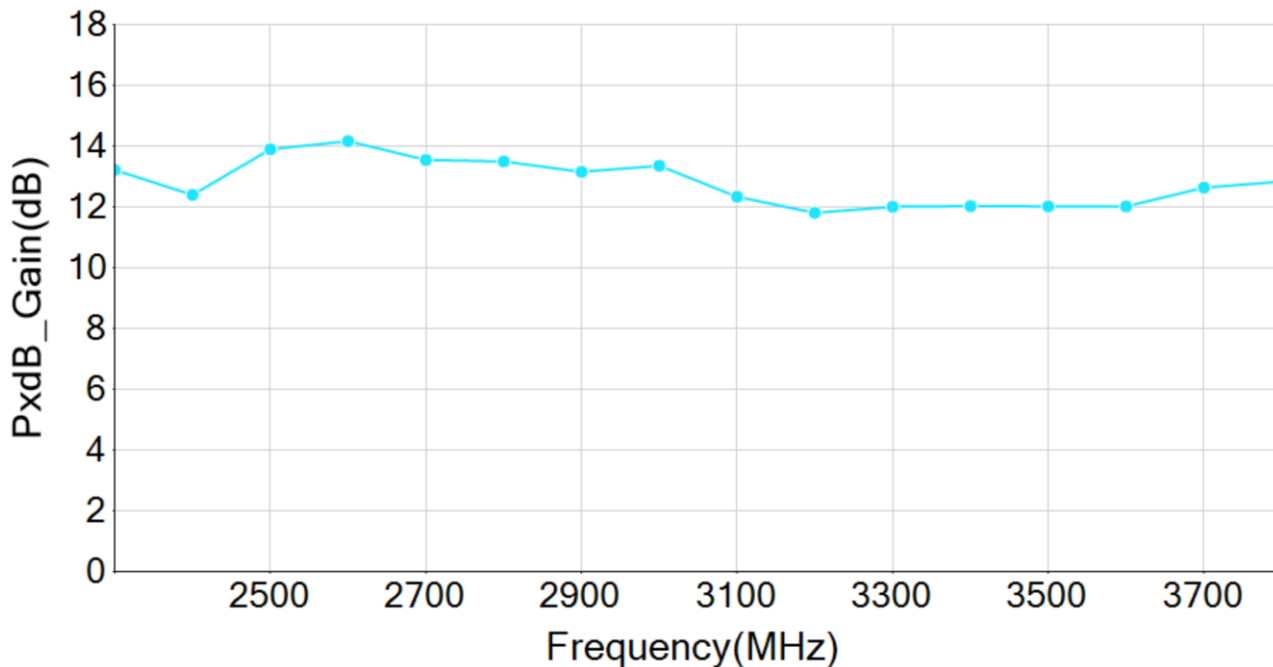

Pout vs. Frequency, 2.5dB Compression

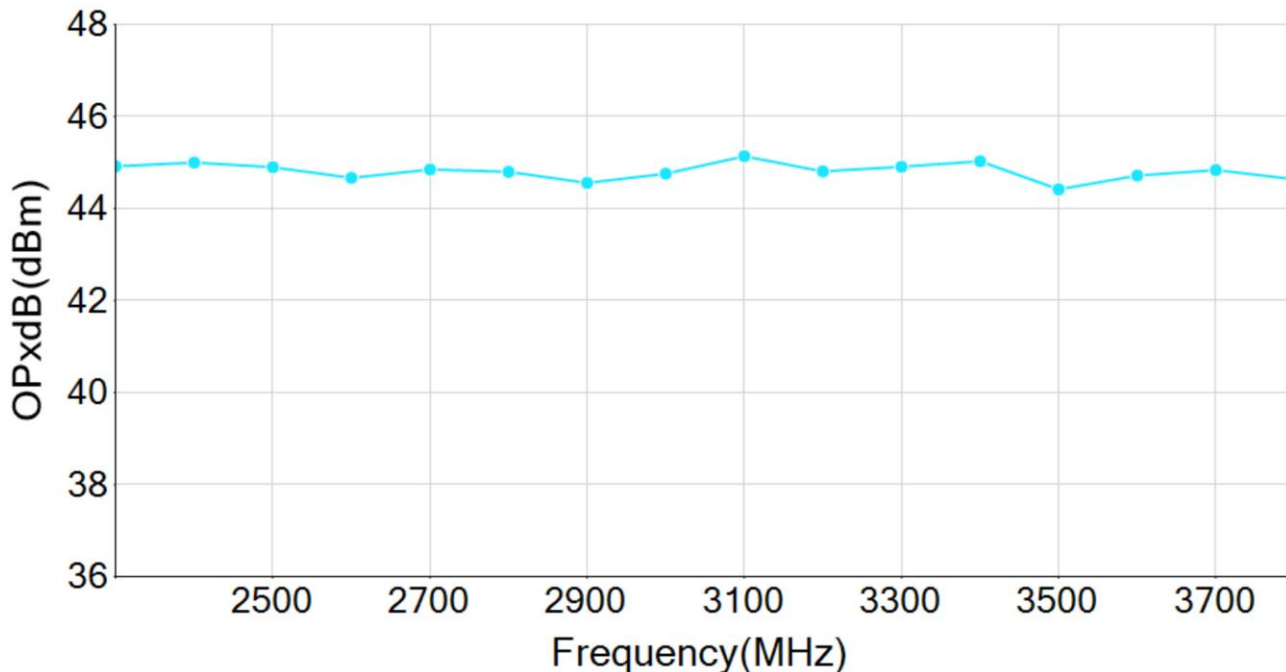

GRF0020 50V, DC – 7.0GHz, 20W GaN HEMT

Drain Efficiency vs. Frequency, 2.5dB Compression

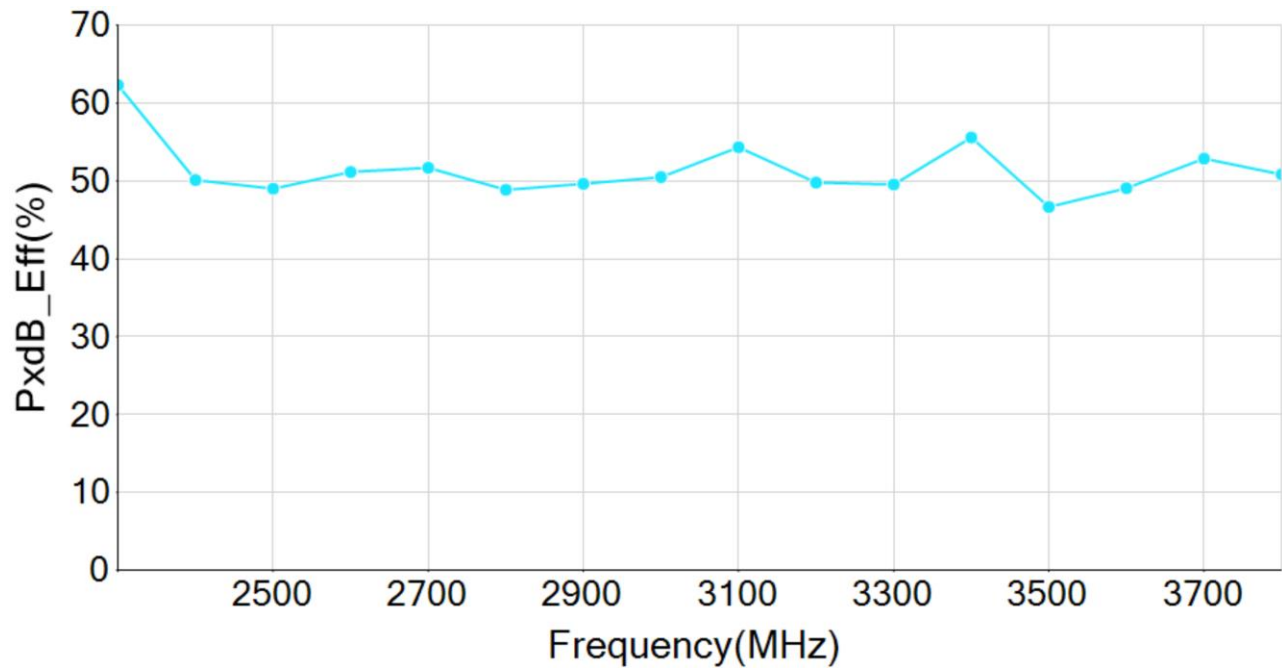

GaN HEMT BIASING SEQUENCE

To turn the transistor ON

1. Set V_{GS} to -5V
2. Turn on V_{DS} to normal operation voltage (50V)
3. Slowly increase V_{GS} to set I_{DQ} current (30mA)
4. Apply RF power

To turn the transistor OFF

1. Turn the RF power off
2. Decrease V_{GS} to -5V
3. Turn off V_{DS} . Wait a few seconds for drain capacitor to discharge
4. Turn off V_{GS}

GRF0020 50V, DC – 7.0GHz, 20W GaN HEMT

PACKAGE DIMENSIONS

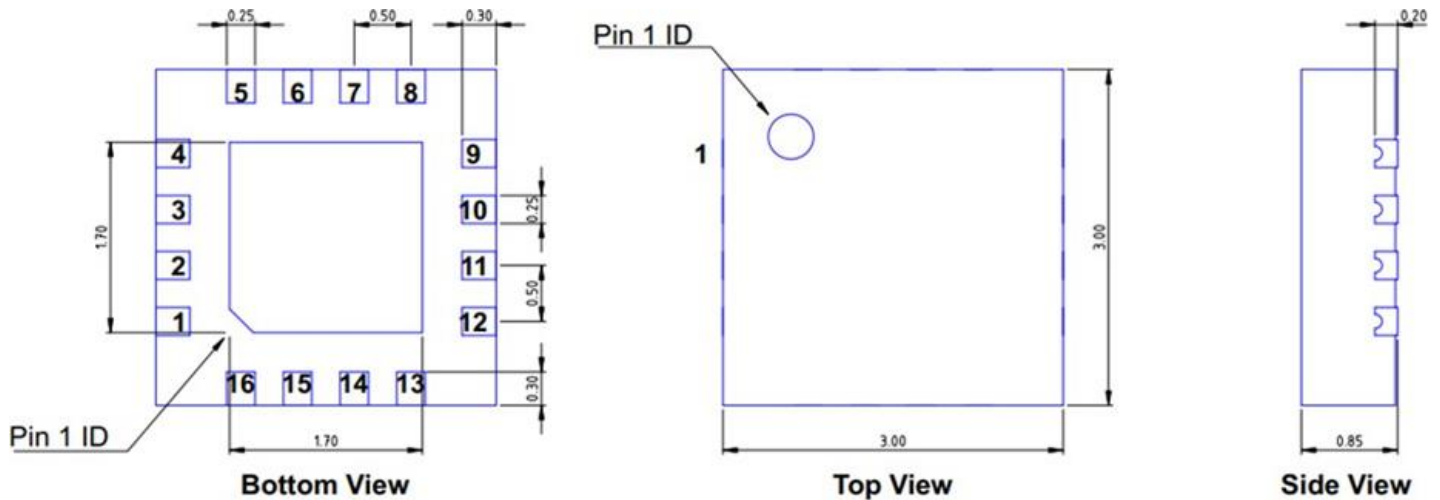

QFN16 3x3mm
 Dimensions in millimeters
 Dimensional Tolerance: ± 0.05

PIN CONFIGURATION

Pin	Input/Output
1, 2, 3, 4	RF Input / Gate Voltage
5, 6, 7, 8,	Ground
9, 10, 11, 12	RF Output / Drain Voltage
13, 14, 15, 16	Ground
17 (Paddle)	Ground

DEVICE LABEL

- Line 1: "YYWW" = Year & Work Week
- Line 2: "GRF" = Guerrilla RF
- Line 3: "XXXX" = Device Part Number

GRF0020 50V, DC – 7.0GHz, 20W GaN HEMT

HANDLING PRECAUTIONS

Parameter	Symbol	Class	Test Methodology
ESD – Human Body Model	HBM	TBD	ANSI/ESDA/JEDEC Standard JS-001
ESD – Charged Device Model	CDM	TBD	ANSI/ESDA/JEDEC Standard JS-002
MSL – Moisture Sensitivity Level	MSL	MSL 1	IPC/JEDEC Standard J-STD-020

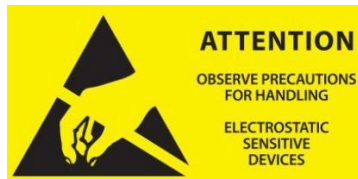

RoHS COMPLIANCE

Guerrilla-RF Policy on EU RoHS available online:

https://www.guerrilla-rf.com/files/ugd/3748d3_1107b9788f9845f78f45d424097c4c97.pdf

REVISION HISTORY

Revision	Date	Data Sheet Status	Modifications
1	09/23/2024	Preliminary	Initial
2	10/23/2024	Preliminary	Updated plots on pages 10, 11 & 12

CONTACT INFORMATION

To request latest information and samples, please contact us at:

Web: <https://www.guerrilla-rf.com/>

Email: sales@guerrilla-rf.com

**GRF0020 50V, DC – 7.0GHz, 20W GaN HEMT****IMPORTANT NOTICE**

Information in this data sheet is specific to the Guerrilla RF, Inc. (“Guerrilla RF”) product identified.

This data sheet, including the information contained in it, is provided by Guerrilla RF as a service to its customers and may be used for informational purposes only by the customer. Guerrilla RF assumes no responsibility for errors or omissions on this data sheet or the information contained herein. Information provided is believed to be accurate and reliable, however, no responsibility is assumed by Guerrilla RF for its use, nor for any infringement of patents, or other rights of third parties, resulting from its use. Guerrilla RF assumes no liability for any data sheet, data sheet information, materials, products, product information, or other information provided hereunder, including the sale, distribution, reproduction or use of Guerrilla RF products, information or materials.

No license, whether express, implied, by estoppel, by implication or otherwise is granted by this data sheet for any intellectual property of Guerrilla RF, or any third party, including without limitation, patents, patent rights, copyrights, trademarks and trade secrets. All rights are reserved by Guerrilla RF.

All information herein, products, product information, data sheets, and data sheet information are subject to change and availability without notice. Guerrilla RF reserves the right to change component circuitry, recommended application circuitry and specifications at any time without prior notice. Guerrilla RF may further change its data sheet, product information, documentation, products, services, specifications or product descriptions at any time, without notice. Guerrilla RF makes no commitment to update any materials or information and shall have no responsibility whatsoever for conflicts, incompatibilities, or other difficulties arising from any future changes.

GUERRILLA RF INFORMATION, PRODUCTS, PRODUCT INFORMATION, DATA SHEETS AND DATA SHEET INFORMATION ARE PROVIDED “AS IS” AND WITHOUT WARRANTY OF ANY KIND, WHETHER EXPRESS, IMPLIED, STATUTORY, OR OTHERWISE, INCLUDING FITNESS FOR A PARTICULAR PURPOSE OR USE, MERCHANTABILITY, PERFORMANCE, QUALITY OR NON-INFRINGEMENT OF ANY INTELLECTUAL PROPERTY RIGHT; ALL SUCH WARRANTIES ARE HEREBY EXPRESSLY DISCLAIMED. GUERRILLA RF DOES NOT WARRANT THE ACCURACY OR COMPLETENESS OF THE INFORMATION, TEXT, GRAPHICS OR OTHER ITEMS CONTAINED WITHIN THESE MATERIALS. GUERRILLA RF SHALL NOT BE LIABLE FOR ANY DAMAGES, INCLUDING BUT NOT LIMITED TO ANY SPECIAL, INDIRECT, INCIDENTAL, STATUTORY, OR CONSEQUENTIAL DAMAGES, INCLUDING WITHOUT LIMITATION, LOST REVENUES OR LOST PROFITS THAT MAY RESULT FROM THE USE OF THE MATERIALS OR INFORMATION, WHETHER OR NOT THE RECIPIENT OF MATERIALS HAS BEEN ADVISED OF THE POSSIBILITY OF SUCH DAMAGE.

Customers are solely responsible for their use of Guerrilla RF products in the Customer’s products and applications or in ways which deviate from Guerrilla RF’s published specifications, either intentionally or as a result of design defects, errors, or operation of products outside of published parameters or design specifications. Customers should include design and operating safeguards to minimize these and other risks. Guerrilla RF assumes no liability or responsibility for applications assistance, customer product design, or damage to any equipment resulting from the use of Guerrilla RF products outside of stated published specifications or parameters.